

A

Flexface Lightbox Half Cover 88mm

Compatible with

- Large
- Medium
- Small

Saled Australia's aluminium extrusions have been developed in collaboration with the experienced and outstanding Australian aluminium company, Capral, utilizing local die-making expertise. In a commitment to sustainability, the aluminium extrusions are crafted from low-carbon aluminium, forming part of a solution to protect our collective future. The supporting bar box arrangement has been modified to accept a more robust support section, allowing for the rapid assembly of main bars, covers, and sail tracks. This modification contributes to the fabrication of the world's most popular flex system.

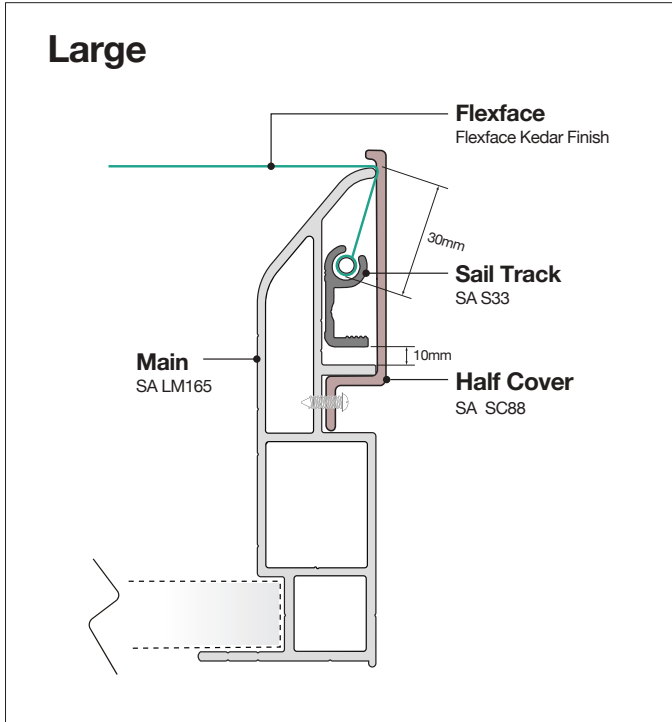

Half Cover SA SC88

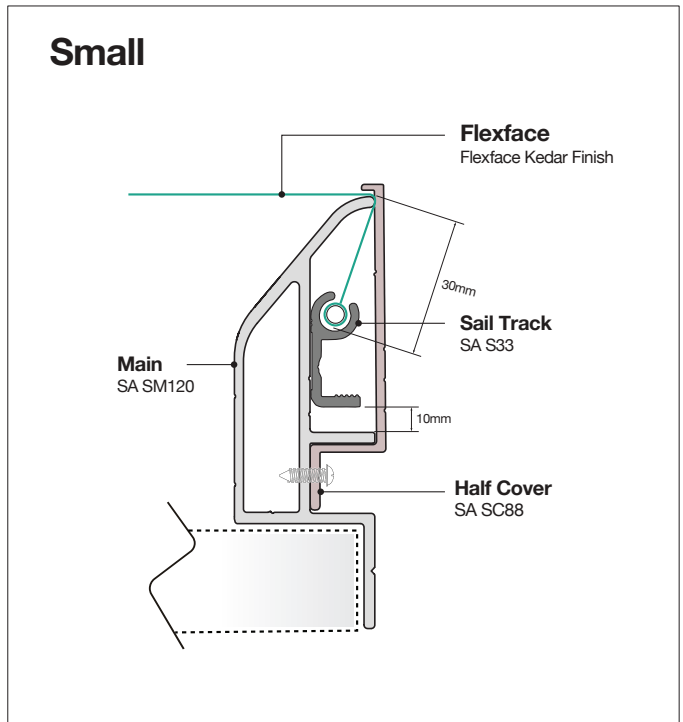
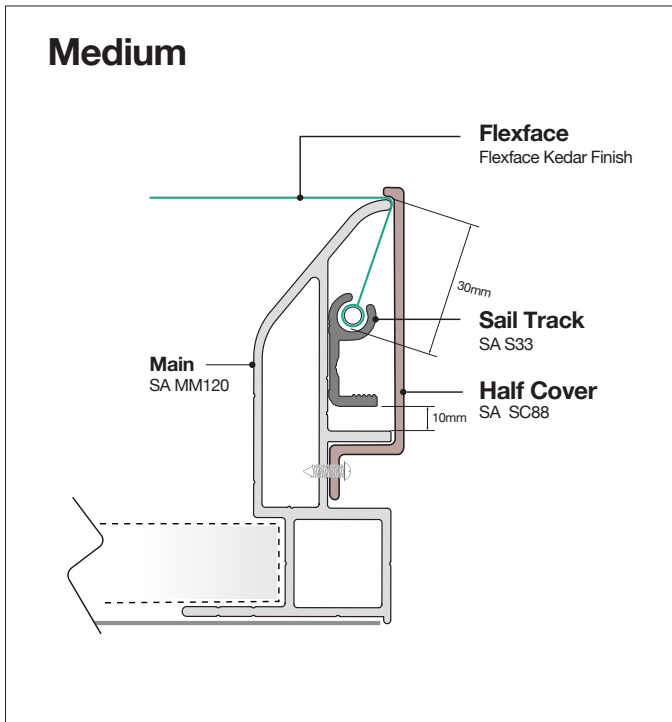
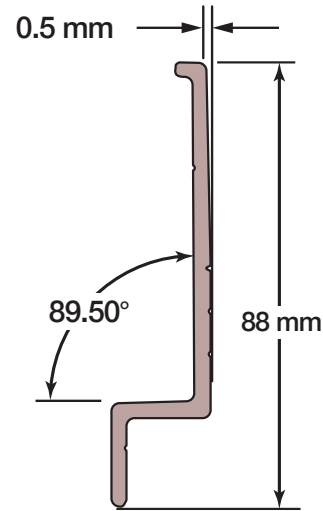

ALL AVAILABLE IN www.sa-led.com

SA-LED

A U S T R A L I A

© Copyright SAled Australia Pty Ltd 2024. All rights reserved.

Sale & Enquiry

TEL +61 7 3219 6711 | 0402 136 631

E-Mail service@sa-led.com

Head Office & Warehouse

40 Wright Place Algester QLD 4115

Mon - Fri 7:30am to 3:30pm